

# Specifications

WindFree™ Pure 1.0 R32 

- Three-step cooling: Fast Cooling mode, Dehumidification mode and WindFree™ Cooling mode.
- PM1.0 Filter.
- AI Auto Comfort.
- Freeze Wash.
- Wi-Fi Control with Samsung SmartThings and Bixby voice controls.
- Compressor with Digital Inverter Boost technology.
- Equipped with NASA communication protocol.
- Direct drive fan powered by a BLDC motor.
- Triple Protector Plus to protect compressor, fan and controller from power surges.



Indoor Unit		AR09AXKAAWKN/EU	ART2AXKAAWKN/EU	
Outdoor Unit		AR09AXKAAWKX/EU	ART2AXKAAWKX/EU	
<b>Capacity</b>				
Capacity	Cooling (Nominal)	kW	2.5	3.5
	Cooling (Min→Max)	kW	0.9-3.4	0.9-4.4
	Heating @ +7°C	kW	3.2	4.0
	Heating (Min→Max)	kW	0.7-6.5	0.7-6.8
	Heating @ -5 °C	kW	TBC	TBC
	Heating @ -10 °C	kW	TBC	TBC
	Heating @ -15 °C	kW	TBC	TBC
<b>Performance</b>				
Energy Efficiency Cooling	SEER <sup>1</sup>	W/W	7.9/ <b>A++</b>	7.2/ <b>A++</b>
	Power Consumption	kWh/a	111	170
	Pdesignc	kW	2.5	3.5
	EER	W/W	4.46	3.80
Energy Efficiency Heating	SCOP <sup>1</sup>	W/W	4.6/ <b>A++</b>	4.6/ <b>A++</b>
	Power Consumption	kWh/a	700	730
	Pdesignh (average)	kW	2.3	2.4
	COP <sup>1</sup>	W/W	3.95	3.71
Moisture Removal		l/h	1.0	1.5
Maximum Airflow (Cooling)	Indoor Unit	m <sup>3</sup> /min	11.7	12.1
	Outdoor Unit	m <sup>3</sup> /min	45	45
Sound Power	Indoor Unit (Cooling)	dB(A)	56	58
	Outdoor Unit (Cooling)	dB(A)	59	62
Sound Pressure	Indoor Unit High/Silent Mode	dB(A)	38/19	40/19
	Outdoor Unit High	dB(A)	45	46
Operating Temperature Range	Cooling	°C	-10-46	-10-46
	Heating	°C	-15-24	-15-24
<b>Electrical Data</b>				
Power Source		Φ, V, Hz	1Ø, 220-240 V, 50 Hz	1Ø, 220-240 V, 50 Hz
Compressor Type	Outdoor Unit	Type	BLDC Rotary	BLDC Rotary
Power Consumption	Cooling	W	560	920
	Heating	W	810	1079
Operating Current	Cooling	A	2.9	4.4
	Heating	A	3.9	5.1
<b>Dimensions</b>				
Net Dimensions (W x H x D)	Indoor Unit	mm	820x345x215	820x345x215
	Outdoor Unit	mm	790x548x285	790x548x285
Net Weight	Indoor Unit	kg	10.3	10.3
	Outdoor Unit	kg	32.5	32.5
<b>Refrigerant</b>				
Refrigerant	Type		R32 (contains fluorinated greenhouse gases. GWP = 675)	
	Charging (for 5 m)	kg	0.965	0.965
	Charging Ton Equivalent CO <sub>2</sub>	tCO <sub>2</sub> e	0.65	0.65
	Additional Refrigerant Charging	g/m	15	15
Piping Connections	Liquid Pipe	ø, mm (inch)	1/4	1/4
	Gas Pipe	ø, mm (inch)	3/8	3/8
Piping Length	Min/Max (ODU to IDU)	m	3/15	5/15
Piping Height	Max	m	8	8
Piping Connections	Drain Pipe	ø, mm	ø16.3, 550 mm	ø16.3, 550 mm



Indoor Unit		AR09AXKAAWKN/EU	ART2AXKAAWKN/EU
Outdoor Unit		AR09AXKAAWKX/EU	ART2AXKAAWKX/EU
<b>Functions</b>			
Airflow	WindFree™ Cooling	•	•
	Air Direction Control (Up/Down)	Auto	Auto
	Air Direction Control (Left/Right)	Auto	Auto
	Auto Fan Speed	•	•
Air Purification	PM1.0 Filter	•	•
	Easy Filter Plus	•	•
	Auto Clean (Self-Cleaning)	•	•
Operating Mode	Freeze Wash	•	•
	AI Auto with Wi-Fi & MDS (direct/indirect)	-	-
Other Functions	AI Auto with Wi-Fi	•	•
	Auto Mode (without Wi-Fi)	-	-
	Fast Cool	•	•
	Good Sleep	•	•
	Eco	•	•
	Dehumidification	•	•
	Fan	•	•
	Quiet	•	•
	Samsung SmartThings	•	•
	MDS (Motion Detect Sensor)	-	-
Indoor Temp. Display	•	•	
Air Quality Indication	•	•	
Display On/Off	•	•	
Beep On/Off	•	•	
Auto Changeover	•	•	
Auto Restart	•	•	

Accessory



Wireless Remote Controller (included)

<sup>1</sup> Energy labels as shown are according to EU No 626/2011 (LOT10) label classification 2019, on a scale from D to A+++.

# Dimensional drawings

WindFree™ Pure 1.0 - Indoor

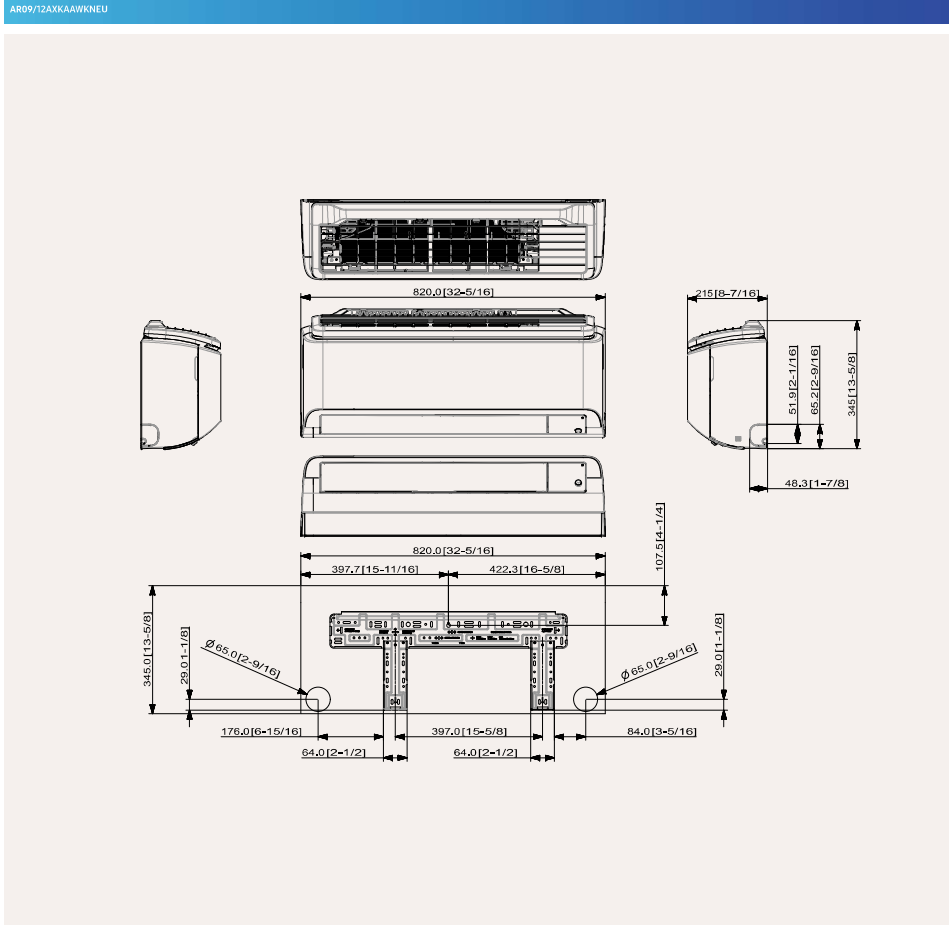

WindFree™ Pure 1.0 - Outdoor

